

EXTRUDER - WIRE CUTTER WCD 300



POLIN
INDUSTRIAL LINE



❑ EXTRUDER AND WIRE CUTTER

❑ WCD 300

The extruder and wire cutter is provided with heavy duty feed roller dosage head , to produce many different biscuits and cookies, wire cut or guillotine cut, and soft center guillotine cut cookies, with accurate weight and shape control and fast changeovers.

The large diameter rolls (300 mm) help to achieve up to 100 mm diameter wire cut cookies, while a plastic filler block underneath ensure a reliable dough extrusion with high weight control across the band.

Rapid removal of die and filler block without tools and hydraulic operated for easy cleaning and fast changeover.

Provided with electrical adjustment of height of the machine up to 150 mm.

Stainless steel hopper and feeding roller, hard anodized aluminium head structure, stainless steel guards and feet of own design.

Working widths:
800 - 1000 - 1200 - 1500 mm.

Servomotor control of all settings:
- Cutting stroke frequency and length
- Height of machine above conveyor band
- Wire distance to die plate
- Feed rollers speeds





□ Wire-cut cookies

The dough placed in the hopper of the machine is continuously extruded by means of the feed rollers that through the plastic filler block pushes the product towards a die plate, provided with nozzles or templates.

An additional oscillating wire attachment allow the wire to oscillate at a high frequency, up to 150 cuts per minute with full adjustment.

Wire-cutting frame fully accessible for a fast change of the full frame.

Particular frame with wire always clean and without sticks, with the possibility of cutting cookies with big inclusion, as American chocolate chips cookies.

Motion of the wire following the horizontal surface of the die plate during the whole cutting motion, with a full control of the drop onto the belt with no deformation of the product and proper alignment length wise and across the belt.

□ Soft center cookies

The machine can be provided with special additional hopper for the filling of liquid or semi-liquid materials inside the main extruded dough.

The extruded dough forced through the filler block towards a diaphragm shutter die forms special cookies with soft center of cream or jam.

Guillotine-cut cookies

The machine can be fitted for extrusion also on an intermediate conveyor, moving on rails to get the double possibility of extruding onto this conveyor or onto the oven belt.

A drive roller can be mounted on the auxiliary conveyor for placement of pattern on the extruded products.

A high frequency guillotine is fitted after that to produce several kinds of bars and cookies.



Soft center guillotine cut cookies

The machine can be provided with special additional hopper for the filling of liquid or semi-liquid materials inside the main extruded dough.

The extruded lanes are cut by the high frequency guillotine to produce special cookies as fig-bar and jam – cream filled biscuits.

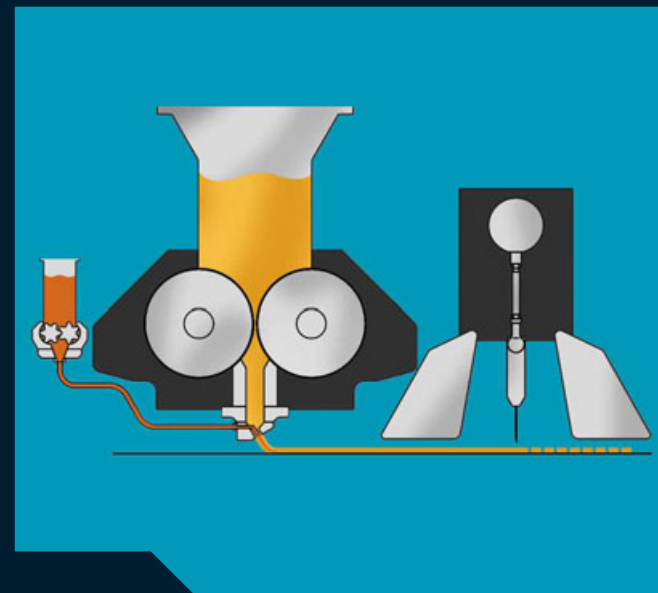



□ Control System

Clear, simple “Touch screen” Operator Panel connected to a PLC to allow the operators to keep under full control the machine running, with recipe-driven set-up and full alarm messages to reduce changeover time, downtime and waste.

Full recipe handling and management, total process visualization, performance historic trends, alarm monitoring and handling, machine parameters and variable control, easy diagnosis

for trouble shooting are the main features make the machine operation fully controlled.

Up-to-date links for Teleservice, as remote control, provided via Internet as VPN, direct dial-up pr GMS modem to get immediate access and assist with problem solving



□ Cleaning

Dosing head has been designed and manufactured in anodized aluminium and AISI 304 stainless steel because they are non-toxic, easy to clean and in compliance with HACCP international standards; motors are waterproof and fitted with connectors that can be sealed with special watertight rings.

Dosing head can be removed from the machine

structure; die plates, nozzles and filler block can be easily removed without tools thanks to an automatic unloading.

Die changes are executed with a fast sideboard sliding of die plates: The wire cut frame is not to be removed during die plate change.



□ Filler block, templates and nozzles

The machine is provided with a huge variety of standard nozzles and templates, all manufactured inside the company, that cover a large number of biscuits and cookies.

Die plate, nozzles and templates can be manufactured individually following any special demand and requirement of the

Customers, using the best food-grade and atoxic materials.

The filler blocks of last engineering allow a proper weight and shape control.

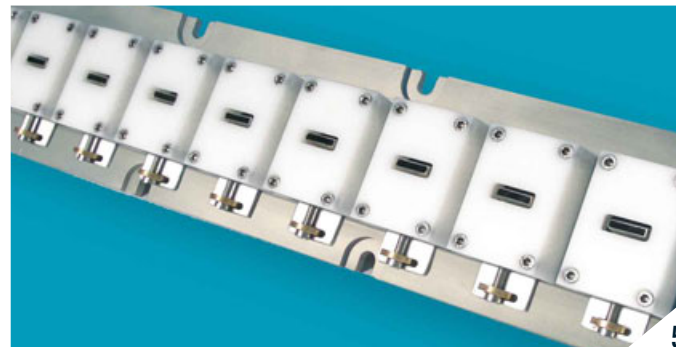
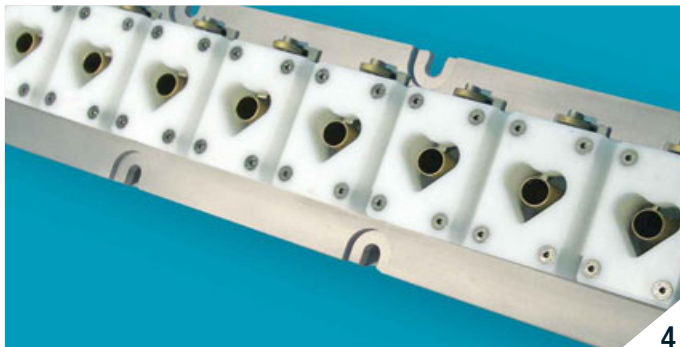
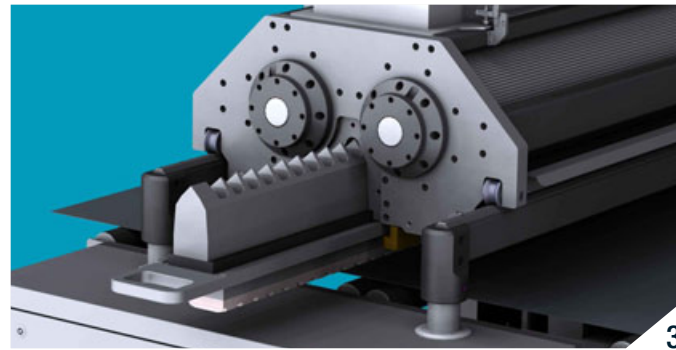
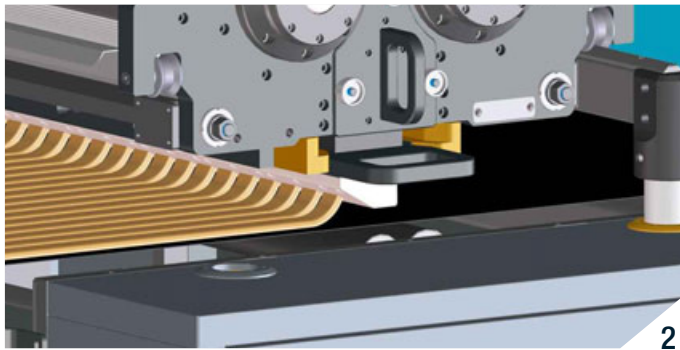

- 1 - Wire cut
- 2 - Extruding die plate
- 3 - Filler block
- 4 - Wire cut die plate
- 5 - Wire cut die plate





Pictures, measurements and technical data are not binding and thus subject to modification with no advance notice.
Immagini, misure e dati tecnici non sono impegnativi, quindi soggetti a modifiche senza obbligo di preavviso.